

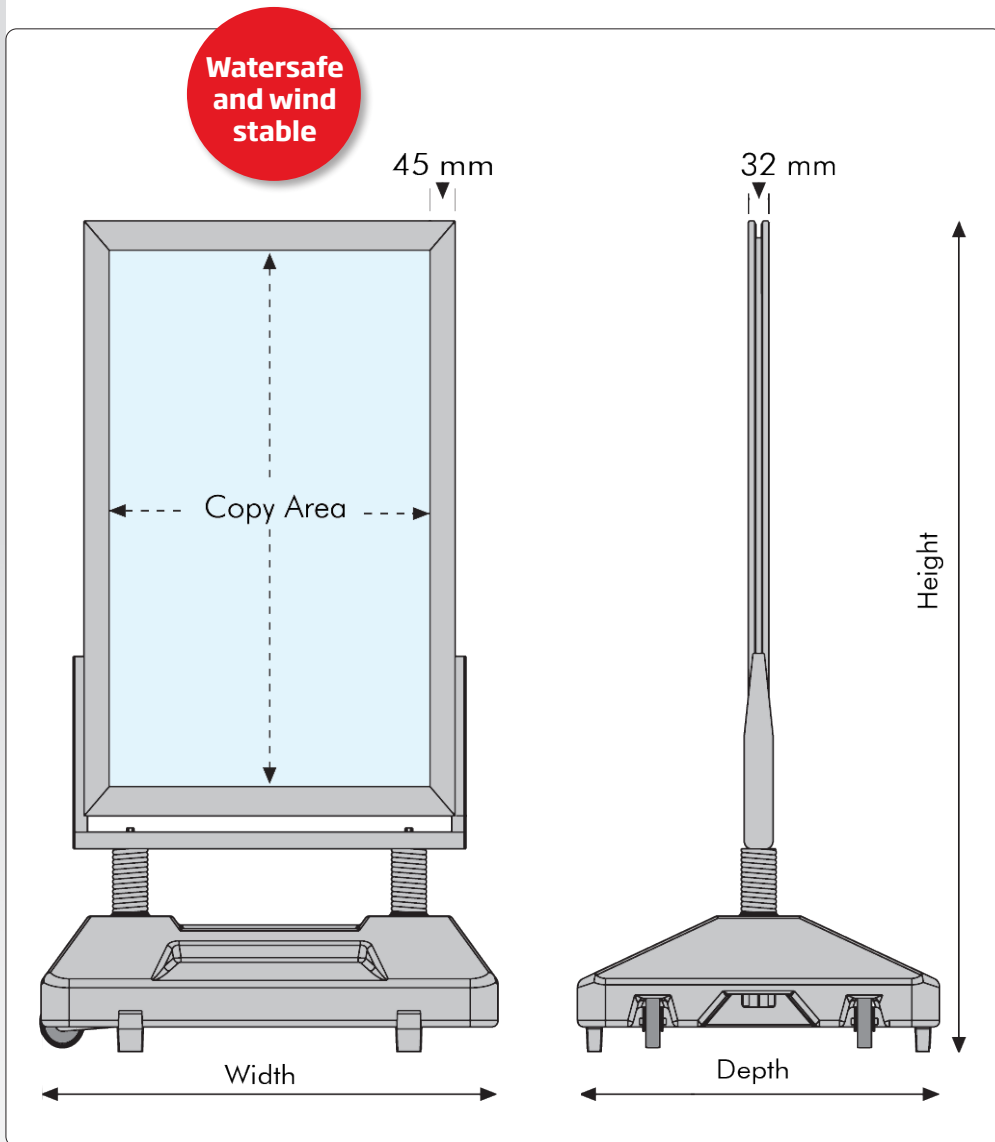

Pavement board with steel springs and aluminum snap-frame with 45 mm profiles and APET anti-reflex front panels. Mounted with black rubber to protect the poster from water. The foot is a 2-wheeled plastic jerry can, to fill with water or sand to make it heavy (28-37 l) - please add anti-freeze if below 0° C degrees.

Strassenständer mit Stahl-federn und 45 mm Alu-profile mit Ecken auf Gehrung. Mit entspiegelte APET Frontplatten. Mit schwarzem Gummi montiert zum Schutz gegen Wasser. Der Fuss mit 2 Rollen besteht aus einem Plastikbehälter in dem Sie Wasser oder Sand füllen können (28-37 Liter) - bei Kältegrade mit Frostschutzmittel nachfüllen.

Gadeskilt med stål-fjedre og 45 mm aluprofiler med geringshjørner. Med antirefleks APET frontplader. Sort skumliste monteret mod indtrængning af vand. Fod med 2 hjul i kraftigt plast, som kan fyldes med sand eller vand (28-37 liter) - i tilfælde af frost, påfyldes frostvæske.

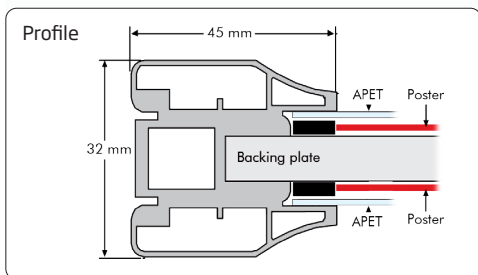
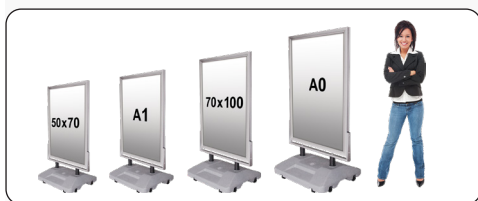

**Waterbase Art.no. 4637:** Weight 8 kg (empty) - filled with water 36 kg. Contains 28 litres.

**Waterbase Art.no. 4635, 4638 & 4636:** Weight 9 kg (empty) - filled with water 46 kg. Contains 37 litres.

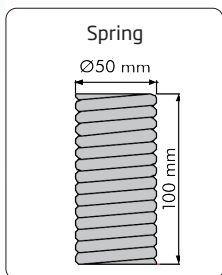
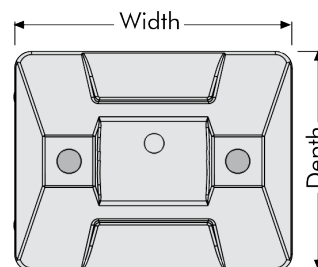

Model	Article	Poster size	Visible part	Color	Total W x H x D	Package size and weight	Pallet size and quantity
127	4637	50 x 70 cm	48,2 x 68,2 cm	Alu/grey	70 x 108 x 55 cm	65 x 105 x 7,5 + 57 x 72 x 24 cm 19 kg	80 x 120 x 220 cm 8 pcs.
127	4635	59,4 x 84,1 cm A1	57,6 x 82,3 cm	Alu/grey	82 x 122 x 65 cm	72 x 120 x 7,5 + 84 x 67 x 24 cm 24 kg	80 x 120 x 220 cm 8 pcs.
127	4638	70 x 100 cm	68,2 x 98,2 cm	Alu/grey	82 x 142 x 65 cm	85 x 135 x 7,5 + 84 x 67 x 24 cm 28 kg	80 x 120 x 220 cm 6 pcs.
127	4636	84,1 x 119 cm A0	82,3 x 117,1 cm	Alu/grey	92 x 160 x 65 cm	99 x 155 x 7,5 + 84 x 67 x 24 cm 29 kg	80 x 120 x 220 cm 4 pcs.

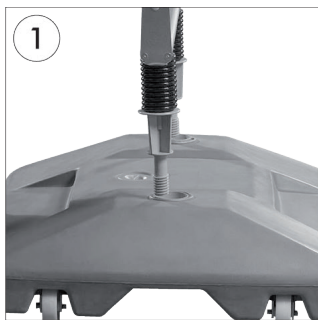

**GB** Place the springs into the holes of the plastic base.

**DE** Setzen Sie die Federn in die Löcher auf dem Wassertank.

**DK** Placer fjederne i hullerne på plastfoden.

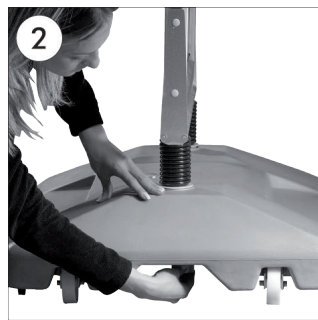

**GB** Fix the base, frame and the springs by tightening the screws with wrench.

**DE** Mit Hilfe eines Maulschlüssels die Schrauben festziehen.

**DK** Skru foden, rammen og fjederne sammen med en skrueøgle.

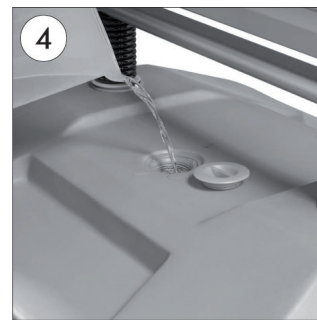
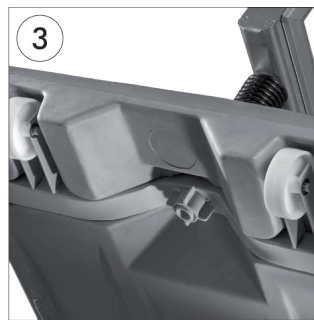

**GB** Fill in the base with water and close the cover cap.

**DE** Drehen Sie den Deckel am Wassertank auf und füllen Sie ihn mit Wasser.

**DK** Fyld plastfoden med vand og skru hættten på igen.



**GB** Open all profiles.

**DE** Alle Profile öffnen.

**DK** Åben profilerne.

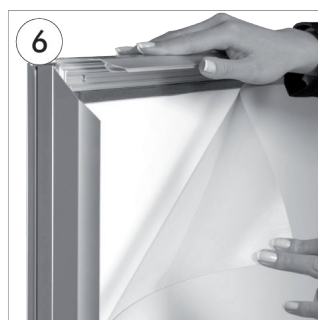

**GB** Take-off the front panel.

**DE** Frontscheibe abheben.

**DK** Løft frontpladen



**GB** Place the poster under the front panel.

**DE** Poster unter Frontscheibe einlegen.

**DK** Læg plakaten ind under



frontpladen.

**GB** Close the profiles.

**DE** Die Seitenprofile zuklappen.

**DK** Luk profilerne.



**GB** Slightly lowering the unit to the wheels side, you can move the board easily.

**DE** Um den Produkt zu bewegen, schieben Sie ihn anhebend in die Richtung der Rollen.

**DK** Skiltet kan let flyttes ved at bøje det ned mod hjulene og trække.

