

Textile top here shown with print



🇬🇧 Event tent in super quality - made of 40 mm - 6-angular aluminum bars. Incl. top of black textile (420D waterproof polyester) without print. For outdoor use. Black trolley incl.

🇩🇪 Faltpavillion in super Qualität - aus 40 mm 6-Eck geformten Aluminium Rohren. Inkl. schwarzen Dach aus 420D wasserdichter Polyester - ohne Druck. Für den Außenbereich. Inkl. schwarzer Trolley.

🇩🇰 Eventtelt i super kvalitet - fremstillet af 40 mm 6-kantede aluminiumsstænger i sølv. Inkl. top af sort tekstil (420D vandtæt polyester) uden tryk. Til udendørs brug. Inkl. sort trolley.



VERY EASY TO POP UP

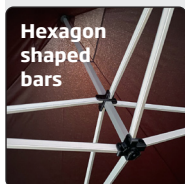

Hexagon shaped bars



Foot with holes for pegs

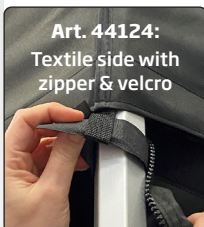

Art. 44124: Textile side with zipper & velcro



Art. 44124: Textile side - 3 m width



Black trolley incl.



Weight disc art. 44140



You can print logo and text on textile 30 cm height x tent width and mount it with velcro band (not incl.)



Weight discs art. 44141



Art. 44124: 2 sides with zipper



Art. 4414: 6 x 3 m with 6 legs



Very easy to pop-up

Takes only 5 min. to pop-up!

Model	Art.no.	Product	Size	Height	Colour	Package size and weight	Pallet size and quantity
472	4411	Event Tent Lux	2 x 2 m	3,25 m	Alu/silver	30 x 30 x 169 cm 19 kg	80 x 120 x 186 cm 8 pcs.
472	4412	Event Tent Lux	3 x 3 m	3,53 m	Alu/silver	30 x 30 x 169 cm 24 kg	80 x 120 x 186 cm 8 pcs.
472	4413	Event Tent Lux	4 x 4 m	4,47 m	Alu/silver	30 x 30 x 215 cm 31 kg	80 x 120 x 192 cm 8 pcs.
472	4414	Event Tent Lux	6 x 3 m	3,53 m	Alu/silver	47 x 28 x 169 cm 34 kg	80 x 120 x 186 cm 6 pcs.
	44124	Textile side with 2 zippers + velcro	3 x 2,10 m		Black		
Spare parts	44117	Textile top for 2 x 2 m tent			Black		
	44127	Textile top for 3 x 3 m tent			Black		
	44137	Textile top for 4 x 4 m tent			Black		
	44147	Textile top for 6 x 3 m tent			Black		
	44140	Weight disc, 1 pc.	10,5 kg				
	44141	Weight discs, 2 pcs.	2 x 8 kg				
	44142	Steel pegs, 4 pcs. with 3,5 m cord	Ø 5 mm				

TENT INSTALLATION INSTRUCTIONS

Please read each step before you attempt set-up!

- 1** Place shelter in center of area to be sheltered. Remove cover. Have 2 people stand on opposite sides, grasp two outer legs, lift off of ground and step backwards, stopping at arms length.

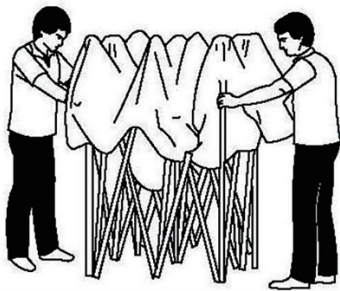

- 2a** Grasp the bottom of the diamond (shown), on opposite sides. Lift up, and step backwards until shelter is fully opened, being careful not to pinch fingers (for 3MX6M shelter see 2b).

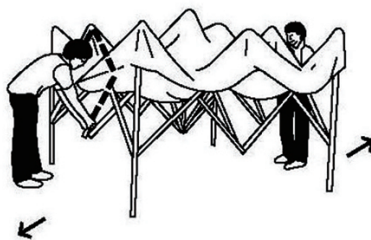

- 2b** (For 3MX6M shelter)
Each person should move to middle leg of 20' side. Grasp at bottom of diamond (shown), lift up and step backwards at the same time until shelter is fully opened, being careful not to pinch fingers at end of truss.

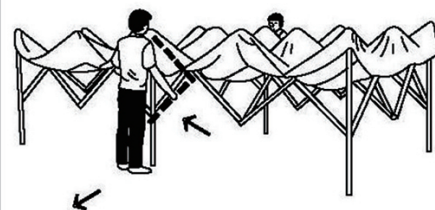

- 3** Engage the auto slider at each corner by pushing up with one hand while holding down top of leg with the other hand. Snap Button will engage in groove. Repeat on all other legs.

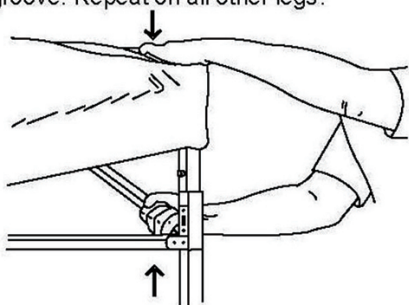

- 4** Lift two adjacent outer legs up and pull out the inner legs until snap locks. Repeat on all legs. Raise or level the shelter using adjustment holes found near bottom of each outer leg.

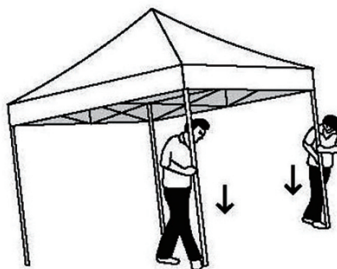

IMPORTANT

- **WINDY CONDITIONS:** Use stake kit or weight bag set
- **HEAVY WIND:** Take shelter down.
- **WET FABRIC:** Let shelter dry before closing.
- **STORAGE:** Use cover bag when not in use.
- **CLEANING:** Use mild detergent and water.
- **RAIN:** Do not leave shelter unattended.

HOW TO TAKE DOWN YOUR TENT

- 1** Lift two outer legs slightly, depress snap button, telescope inner legs up into outer legs. Repeat on opposite side.

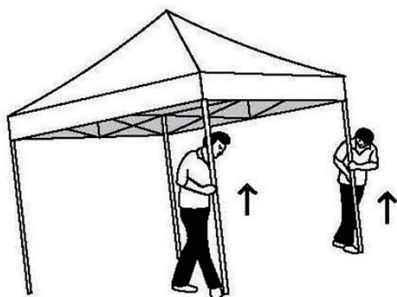

- 2** Release auto slider at each corner by pushing Snap-Button to release pressure on slider. Repeat on all four corners.

RELEASE SNAP-BUTTON

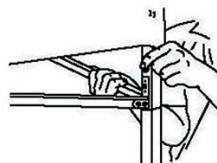

- 3** Grasp top of diamond on opposite sides, lift up, shake shelter a little while stepping towards partner until unit is ¾ closed. Grasp two outer legs, push together to fully close (do not pinch fingers). Put on cover bag.

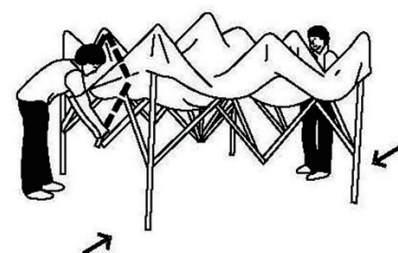

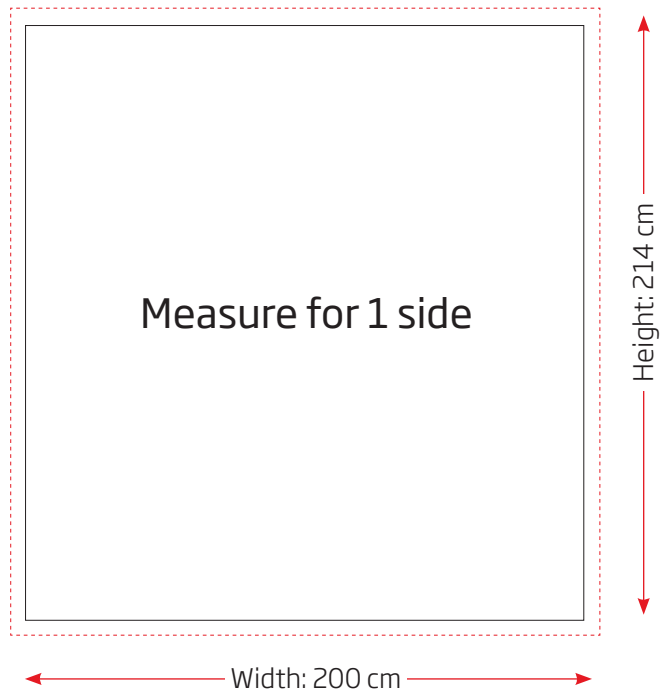
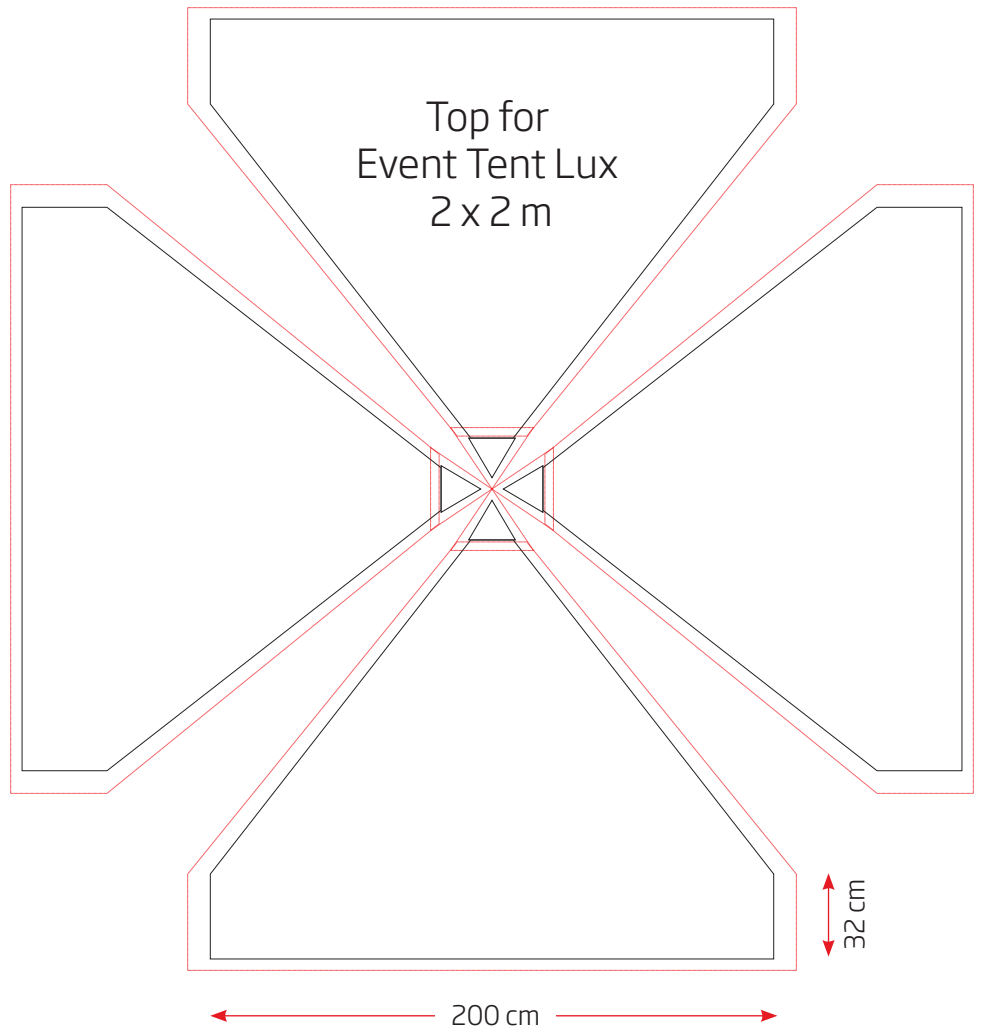
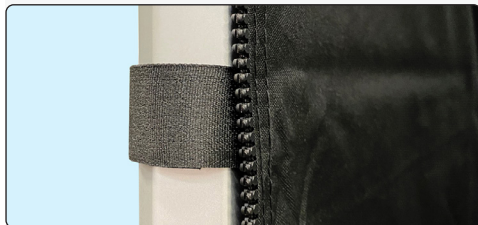
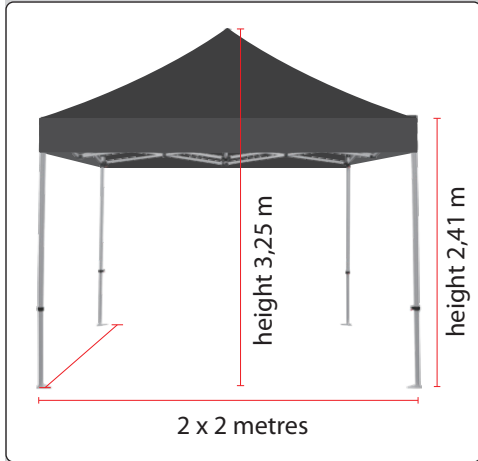

The measure and the black stroke is the finale size after sewing.
The red dotted line is approx. 3 cm extra material for printing bleed and sewing.

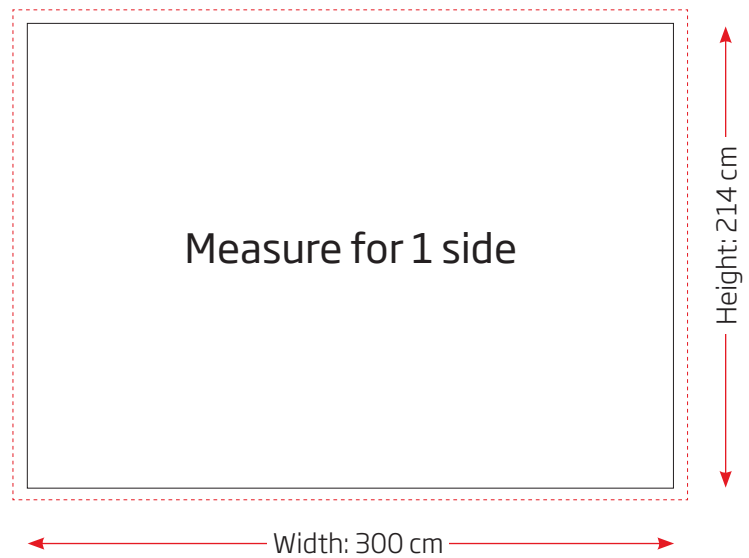
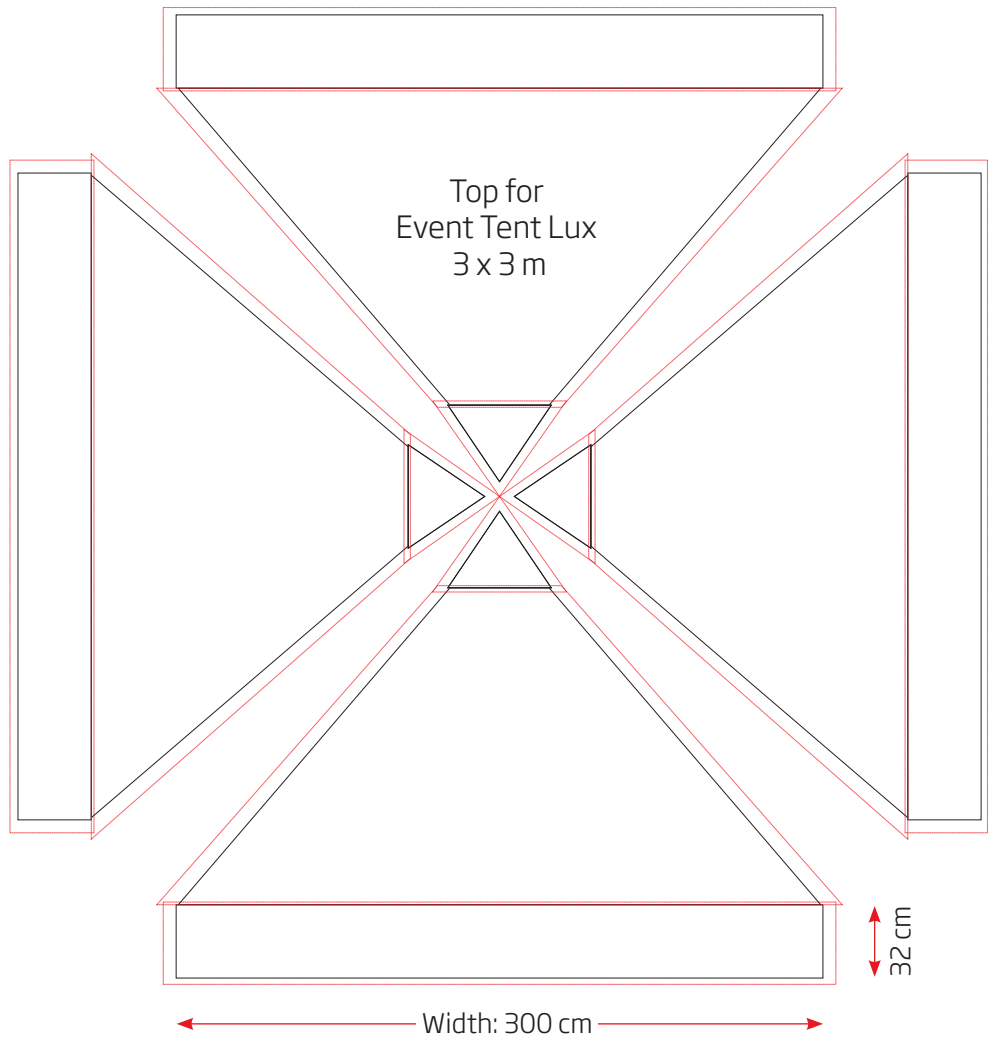
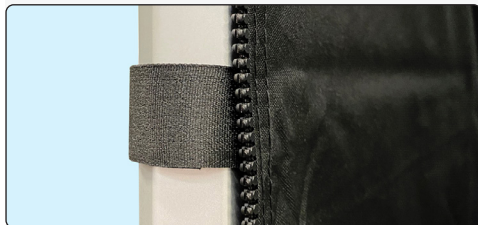
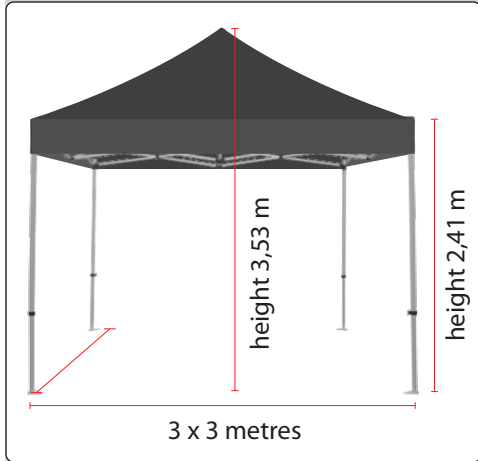

The measure and the black stroke is the finale size after sewing.
The red dotted line is approx. 3 cm extra material for printing bleed and sewing.

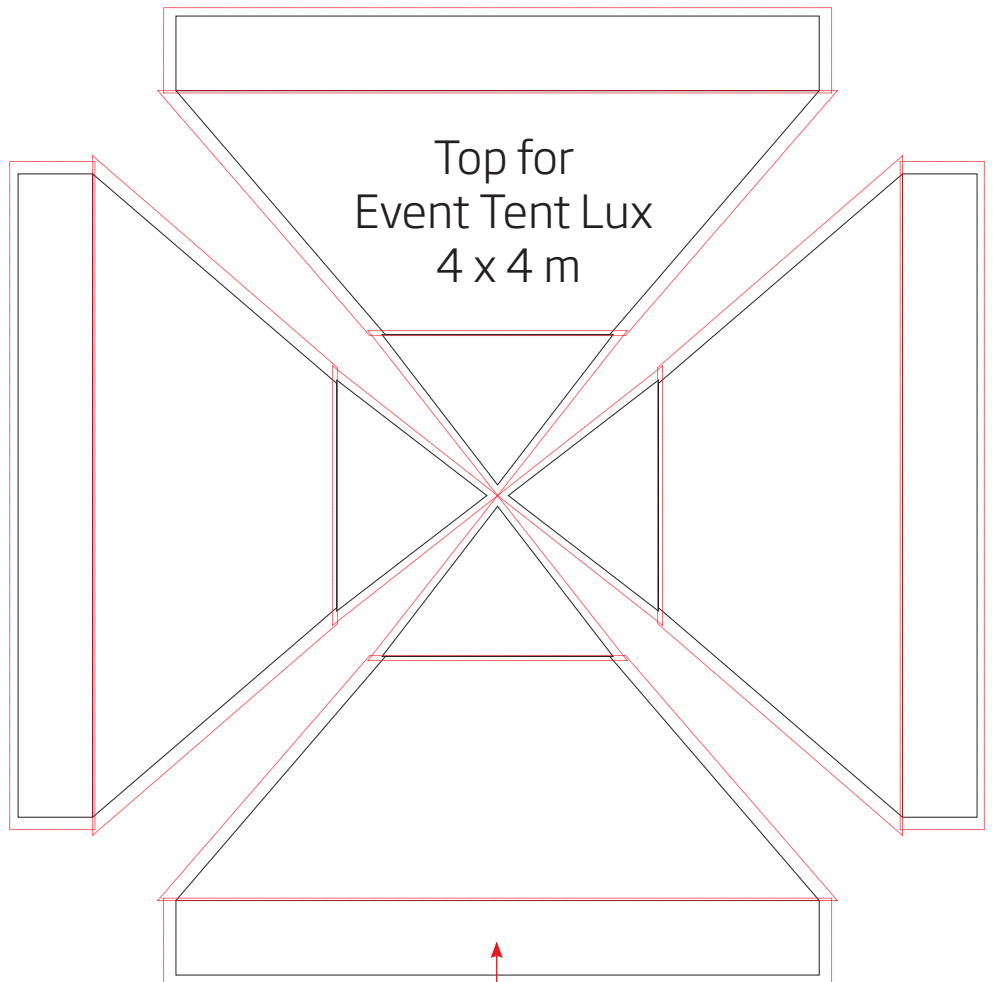
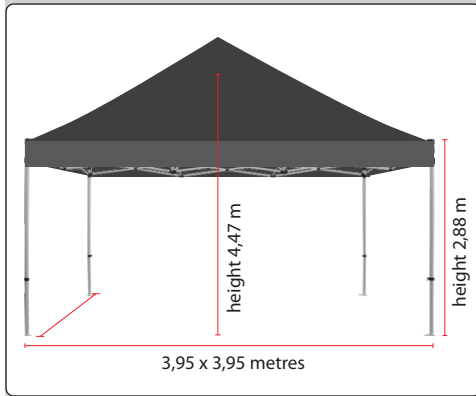

Notice that the original cutfile drawing is made in 50% size !!!

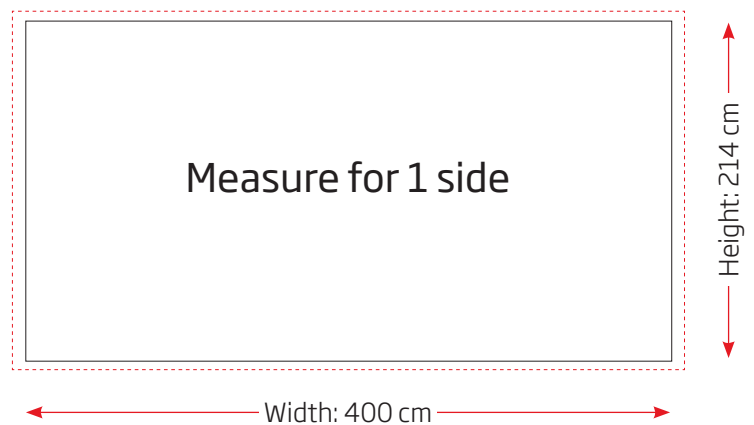

The measure and the black stroke is the finale size after sewing.
The red dotted line is approx. 3 cm extra material for printing bleed and sewing.

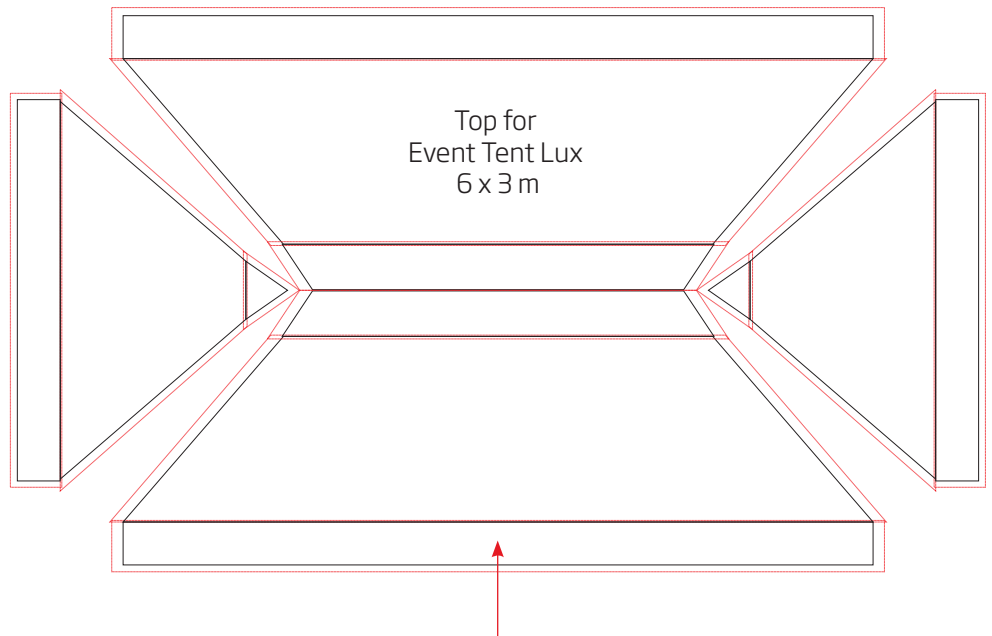
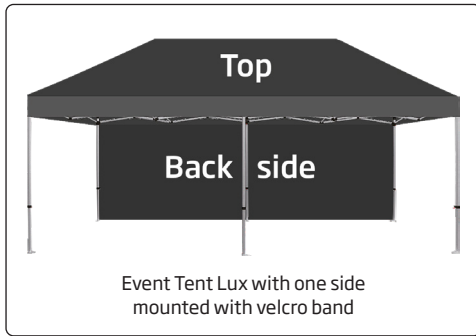
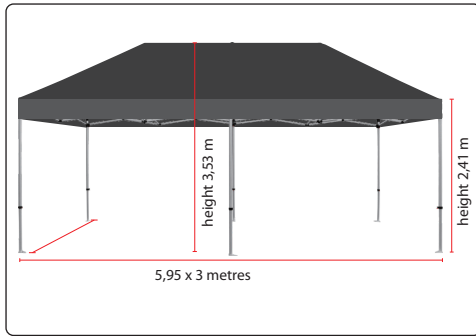

Notice that the original cutfile drawing is made in 50% size !!!

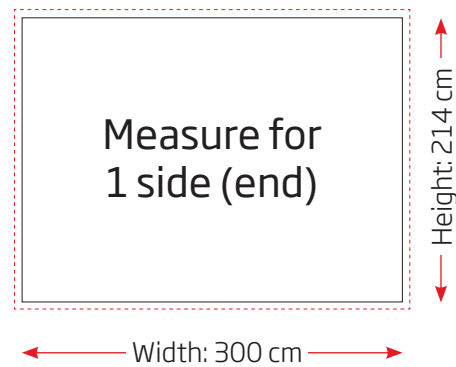
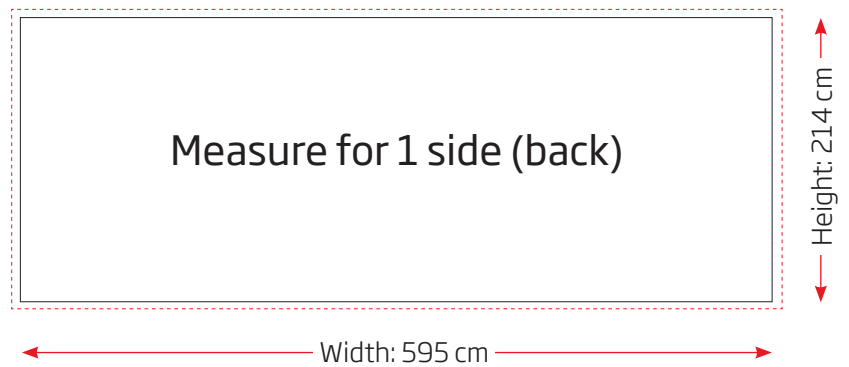

The measure and the black stroke is the finale size after sewing.
The red dotted line is approx. 3 cm extra material for printing bleed and sewing.